

Air Conditioning

Product Information

MFZ-KJ25VE Inverter Heat Pump
Floor Mounted System

Making a
World of
Difference

M series



The MFZ-KJ series is extremely versatile and is designed for wall attached installation at floor level.

Key Features

- Swing Vane Mode with Auto Vane Shutter
- Infra-red remote controller
- Econo Cool - allows set temperature to be raised by 2°C without any loss of comfort and a 20% gain in energy efficiency
- Auto-Restart
- Quiet operation
- Auto-Changeover
- Hot Start - draught prevention
- Anti-Allergy Enzyme filter - artificial enzymecatalyst on the filament catches allergens
- Replace Technology available



Air Conditioning | Heating
Ventilation | Controls

Air Conditioning

Product Information

MFZ-KJ25VE Inverter Heat Pump Floor Mounted System

Making a
World of
Difference

MFZ-KJ - INDOOR UNIT		MFZ-KJ25VE
CAPACITY (kW)	Heating (nominal)	3.4 (1.2-4.6)
	Cooling (nominal)	2.5 (0.5-3.4)
	Heating (UK)	2.85 (0.75-4.25)
	Cooling (UK)	2.5 (0.9-3.35)
SHF (nominal & UK)		0.66
COP / EER (nominal)		4.42 / 4.63
SCOP / SEER (BS EN14825)		4.5 / 8.5
ErP ENERGY EFFICIENCY CLASS Heating/Cooling		A+ / A+++
AIRFLOW (l/s)	Heating/Cooling - Lo-Mi-Hi-Sup-Hi	83-103-127-157 / 80-97-118-148
PIPE SIZE mm (in)	Gas	9.52 (3/8")
	Liquid	6.35 (1/4")
SOUND PRESSURE LEVEL (dBA) Heating/Cooling - Lo-Mi-Hi-Sup-Hi		19-25-30-35-41 / 20-25-30-35-39
SOUND POWER LEVEL (dBA)		49
DIMENSIONS (mm) Width x Depth x Height		750 x 215 x 600
WEIGHT (kg)		15
ELECTRICAL SUPPLY		Fed by Outdoor Unit
FUSE RATING (BS88) - HRC (A)		6
INTERCONNECTING CABLE No. CORES		4

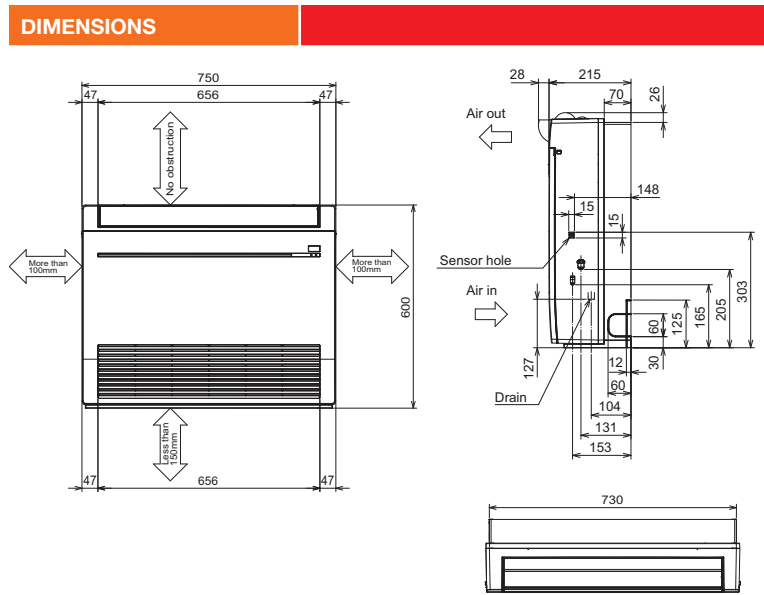

MUFZ-KJ - OUTDOOR UNIT		MUFZ-KJ25VE
SOUND PRESSURE LEVEL (dBA)	Heating/Cooling	51 / 46
SOUND POWER LEVEL (dBA)	Cooling	59
WEIGHT (kg)		37
DIMENSIONS (mm) Width x Depth x Height		800 x 285 x 550
ELECTRICAL SUPPLY		220-240v, 50Hz
PHASE		Single
SYSTEM POWER INPUT (kW)	Heating/Cooling (nominal)	0.77 / 0.54
	Heating/Cooling (UK)	0.70 / 0.43
STARTING CURRENT (A)		3.60
SYSTEM RUNNING CURRENT (A) Heating/Cooling [MAX]		3.6 / 2.7 [9.4]
FUSE RATING (BS88) - HRC (A)		10
MAINS CABLE No. CORES		3
MAX PIPE LENGTH (m)		20
MAX HEIGHT DIFFERENCE (m)		12
CHARGE R410A (kg) - 7m		0.8



Telephone: 01707 282880

email: air.conditioning@meuk.mee.com web: www.airconditioning.mitsubishielectric.co.uk

UNITED KINGDOM Mitsubishi Electric Europe Living Environmental Systems Division
Travellers Lane, Hatfield, Hertfordshire, AL10 8XB, England General Enquiries Telephone: 01707 282880 Fax: 01707 278881

IRELAND Mitsubishi Electric Europe Westgate Business Park, Ballymount, Dublin 24, Ireland
Telephone: Dublin (01) 419 8800 Fax: Dublin (01) 419 8890 International code: (003531)

Country of origin: United Kingdom - Japan - Thailand - Malaysia. ©Mitsubishi Electric Europe 2015. Mitsubishi and Mitsubishi Electric are trademarks of Mitsubishi Electric Europe B.V. The company reserves the right to make any variation in technical specification to the equipment described, or to withdraw or replace products without prior notification or public announcement. Mitsubishi Electric is constantly developing and improving its products. All descriptions, illustrations, drawings and specifications in this publication present only general particulars and shall not form part of any contract. All goods are supplied subject to the Company's General Conditions of Sale, a copy of which is available on request. Third-party product and brand names may be trademarks or registered trademarks of their respective owners.



Note: The fuse rating is for guidance only. Please refer to the relevant databook for detailed specification. It is the responsibility of a qualified electrician/electrical engineer to select the correct cable size and fuse rating based on current regulation and site specific conditions. Mitsubishi Electric's air conditioning and heat pump systems contain fluorinated greenhouse gases R410A, R407C and R134a.



www.greengateway.mitsubishielectric.co.uk

Mitsubishi Electric UK's commitment
to the environment

Follow us @meuk_Jes
Follow us @green_gateway

Mitsubishi Electric
Living Environmental Systems UK

mitsubishielectric2

Effective as of April 2015